

**INTERNATIONAL 110 CLASS
ASSOCIATION**

HANDBOOK
OF
RULES and REGULATIONS



Revised October 2018

TABLE of CONTENTS

Constitution	C-1
Deeds of Gift	G-1
Rules and Regulations Governing The International Championships	R-1
Sail Regulations	S-1
Rules and Specifications	T-1
Measurement Certificate and Measurement Data (M1) Form	T-12

CONSTITUTION

ARTICLE I Name

The name of this organization shall be: THE INTERNATIONAL 110 CLASS ASSOCIATION.

ARTICLE II Emblem

The emblem shall be the numerals – 110 upon which the shape of a 110 is superimposed.

ARTICLE III Object

1. The object is to promote racing of International 110 Class yachts; to maintain uniformity of all 110 Class yachts in "one-design" construction and sail plan; and to adopt and enforce rules and regulations to insure equality in racing competition.
2. To cooperate with and aid individuals and groups in the formation of Fleets, and to require, in return, observance of such rules and regulations as are set down by this Association.
3. The Association is not organized for and shall not be conducted for profit.

ARTICLE IV Membership

1. **Active Member** - An active member is defined as:
 - a. The owner or bona fide individual charterer of a 110 conforming to the Class Plans, Rules and Specifications, having paid dues with respect to such 110 for the then current fiscal year.
 - b. Collectively, a club, association or syndicate or bona fide part owners or charterers of a 110 conforming to the Class Plans, Rules and Specifications, each skipper having paid dues with respect to such 110 for the then current fiscal year. One active membership (entitled to one vote only) may be issued to such an organization or part owners or charterers with respect to each 110 owned or chartered.
 - c. Any such owner, bona fide individual charterer, club, association or syndicate or part owners or charterers may apply for active membership in the Association by written application to the Secretary/Treasurer, together with payment of dues for the then current fiscal year.
Such application with dues may, in the alternative, be submitted through the Fleet in which such 110 normally sails. Any application is subject to refusal for cause by the Governing Committee.
2. **Associate Member:** Anyone who wishes to aid and participate in the activities of the Association, and who is not individually qualified for active membership, may become an associate member. An associate member, as such, may not vote.

3. **Honorary Member:** A lifetime honorary membership in the Association may be awarded to an individual who has rendered outstanding service to the Association or who has contributed significantly to the achievement of the objects for which the Association is formed. Such honorary membership may be conferred at the Annual Meeting upon unanimous recommendation by the members of the Governing Committee there present and by the majority vote of the Fleets there present. An honorary member shall, in all respects, have the same privileges and rights as an active member, but shall not be required to pay dues.

ARTICLE V Districts and Fleets

1. **The Fleet:** The Fleet is the local unit of the Association, composed of members of, and subject to the jurisdiction of, the Association. The Fleet shall promote and encourage the construction, ownership and racing of 110s in its locality. It shall supervise and regulate the racing of 110s in its locality, so that the same shall be conducted in accordance with the rules and specifications of the Association. It shall be responsible for: the measurement of yachts and sails, the collection of Association dues and the implementation of Class policy at the local level. It shall elect its own officers, one of whom shall be designated "Fleet Captain" and another "Fleet Secretary".
2. **Fleet Charter:** Three or more active members who are the owners of three or more 110s, which regularly sail together in a locality where a fleet is not then in existence, may apply to the Association Secretary/Treasurer for a Fleet charter. Notice of such application shall be given to the Governing Committee. The Governing Committee shall promptly act upon such application, and if its action is favorable, the Secretary/Treasurer shall issue a Fleet charter to the applicants. If an existing Fleet at any time ceases to meet the requirements for a Fleet charter, its charter may be revoked by the Governing Committee.
3. **Districts:** The District is the regional unit of the Association and has purposes similar to those of the Fleet at the regional level. The Governor of each District shall appoint a District Secretary to hold office until the next Annual Meeting and until a successor is fully designated. The District Secretary shall assist the District Governor in the performance of the Governor's duties and, in addition to such duties as may be assigned by the Governor, shall be responsible for seeing that all Fleets within the District have assisted in the collection of dues and have duly filed their annual reports with the Secretary/Treasurer.

ARTICLE VI Dues

Active membership dues are \$30 and Associate membership dues are onehalf of active membership dues (\$15.). All dues are payable for a fiscal year beginning January 1st, and ending December 31st. Dues shall be forwarded to the Secretary/Treasurer, postmarked or delivered on or before May 1st of the current fiscal year. Dues may be forwarded through a Fleet officer, together with a list of the names, addresses, and yacht numbers of all members for whom dues are submitted, but it is the responsibility of each member to see that dues are paid to the Secretary/Treasurer on time. Payment to a Fleet officer does not fulfill this requirement. The deadline for dues payment shall be May 1st of each year. Dues postmarked or handdelivered after that date except for new memberships, shall include a late penalty of \$10.

ARTICLE VII Fleet Reports

1. Each fleet shall file the following reports annually:
 - a. Report of election of Fleet officers not later than January 15th of each year. Report to be filed with the Secretary-Treasurer.
 - b. Report on the collection of Association dues to be filed by July 20th of each year with the Secretary/Treasurer. Such report to include a Fleet roster listing yacht numbers, yacht names, each owner's and/or charterer's name and current mailing address (including zip code), telephone number and email address.
 - c. Reports to the Secretary/Treasurer and the Publicity Chairman on race results and other fleet news from time to time. Report at the conclusion of the season to said officers on the racing results for the season which has concluded.
 - d. Report immediately to the Secretary/Treasurer any changes or additions to the Fleet report.
 - e. A copy of each of the foregoing reports shall be provided to the Publicity Director.
2. Failure to file the above described reports in a timely manner shall be grounds for suspension of a Fleet charter.

ARTICLE VIII Officers and Duties

The Association shall be governed by the following officers. The officers shall be elected at the Annual Meeting, to assume duties the following January 1st, and all officers (except as provided in paragraph one below) serve until their successors are duly chosen and take office.

- 1. The President:** The President is the chief executive officer of the Association. He shall preside at meetings, rule on procedure and appoint special committees. He shall be empowered to call special meetings in accordance with Article X hereof. He shall oversee the functioning of the Association at all levels. In the event that any elected or appointed official of the Class shall be negligent or repeatedly dilatory in the performance of their duties as such official or in the event of a vacancy in any such office, the President shall appoint a successor or replacement to such official, and shall notify the Secretary/Treasurer of such action. The person so appointed shall thereupon have all the powers and duties of the official whom he replaces, and the papers and records pertaining to such office shall forthwith be turned over to such appointee. The President also shall appoint (a) a Class Historian, whose duties include to locating and consolidating all class memorabilia and correspondence, to preserve these for posterity and relieve the Class Secretary from storing outdated material; (b) a Masters Championship Chairman, whose duties include organizing and promoting the Masters Championship Regatta in accordance with Article XV hereof; (c) a Youth Championship Chairman whose duties include organizing and promoting the Youth Championship Regatta in accordance with Article XVI hereof; and (d) other chairmen and committees as he deems appropriate.

The President shall at a reasonable time before the Annual Meeting appoint a Nominating Committee composed of members of the Association, who shall recommend a slate of officers for election at the Annual Meeting. The President shall report to the Annual Meeting on the activities and accomplishments of the Class over the preceding year.

In addition to fulfilling the above executive functions, the President shall promote the popularity of the 110 and growth of the Class through the increase in number of active 110s and active 110 Fleets.

- 2. The First Vice-President:** The First Vice President shall assist the President in the performance of the President's duties and shall officiate, in the absence of the President, at Class meetings. In the event that the President shall be negligent or repeatedly dilatory in the performance of the duties of the office, or if there is a vacancy in said office, the First VicePresident and the Second VicePresident shall, successively, after an affirmation vote of the majority of the Governing Committee then in office, become President of the Association.

3. **The Second Vice President:** The Second Vice President shall assist the President in the performance of the President's duties and shall officiate at Class Meetings in the absence of the President and the First Vice President.
4. **The Secretary/Treasurer:** The Secretary shall: keep the records of the Association, including minutes of meetings, Fleet reports, membership records, records of registration of yachts; register new yachts and assign them official Association numbers; solicit and receive Fleet reports; circularize correspondence and other communications pertaining to the affairs of the Association among the members of the Governing Committee; answer correspondence relative to the Association or shall refer it to other officers for action and answer; and issue all Fleet charters.

The Treasurer shall: collect and deposit all dues and other Class receipts in Association checking or savings accounts; timely collect Association dues and on or before the first of June, and again shortly after July 1, supply all fleets with a list of the names and yacht numbers of active members who have paid current dues as of such dates; promptly make disbursements for expenditures which he/she determines to have properly been incurred by Association officers or which have been duly authorized by the President or a majority of the Governing Committee; be responsible for the financial wellbeing of the Association; and promptly call attention to expenditures incurred on behalf of the Association which he/she determines to be individually or collectively excessive; maintain a roster of members of the Association; prepare and submit a current financial report at the Annual Meeting; publish a balance sheet and income statement for the preceding fiscal year in the Class Newsletter within sixty days of the termination of such fiscal year; and render a current financial statement upon request of any member of the Governing Committee.

5. **The Class Publicity Chairman:** The Publicity Chairman shall: prepare at suitable intervals, preferably at least quarterly, a Class Newsletter which shall be distributed to all active, honorary and associate members and to such persons, newspapers and magazines as the Publicity Director may determine to be advisable in the interest of promoting 110s and the Association. The Publicity Chairman may prepare such other promotional material advisable for such purposes. The Publicity Chairman shall lend every effort to insure that the 110 and the 110 Class are given frequent and full coverage in the news media.
6. **The Technical Chairman:** The Technical Chairman shall: interpret the Class Rules and Specifications, plans and sail regulations and determine the form and content of both the Measurement Certificate and the Form M1 "Measurement Data" for the International Championship Regatta; keep a copy of the measurement certificate for each 110; from time to time propose such changes in the Class measurements, Rules and Specifications, deemed advisable, which, if approved by a majority vote of the Governing Committee or by a majority vote at an Annual Meeting, shall be submitted to the active members of the Association for approval or rejection; and see that all new 110s are promptly weighed and measured and conform in all respects with the plans and Rules and Specifications. The Technical Chairman may also appoint a technical committee to assist with technical issues and measurement of

boats.

7. **The District Governors** There shall be a governor from each District established by the Association. The District Governor shall: supervise and oversee Class activity within the District; be responsible for the orderly scheduling of Class events; see that each Fleet within the District discharges its obligations to the Association, and coordinate and implement Class policy, publicity and activity within the District. Each District Governor shall be elected to represent the District within which such Governor resides. In addition, there shall be a Governor-at-Large who shall be the immediate past-President of the Association.
8. **The Web Master** – Shall manage the design, function, content and day to day operation of the 110 Class online presence.

ARTICLE IX Governing Committee

The powers of the Association shall be vested in and administered by its Governing Committee, which shall consist of the President, VicePresidents, Secretary/Treasurer, Publicity Chairman, Technical Chairman, District Governors, Governor-at-Large and Web Master. An affirmative vote of a majority of the members of the Governing Committee then in office shall decide all questions within the Committee's jurisdiction. In the event of a tie vote, the President shall cast an additional deciding vote. The Governing Committee is empowered to finally determine all questions of the Association and Class policy. In addition, it shall interpret this Constitution, shall grant and revoke Fleet charters and sanction or ban Association races.

ARTICLE X Meetings and Elections

1. The Annual Meeting of the Class shall be held at the location and at the time of the International Championship races. No notice of the Annual Meeting need be given other than as part of the announcement of the events to take place during such International Championship races. If necessary, a special meeting may be held in lieu of and for the purposes of the Annual Meeting. The order of business at the Annual Meeting shall be as follows:
 - a. Call of the meeting to order.
 - b. Roll call of Fleets and officers present.
 - c. Reading of minutes of preceding Annual Meeting and of any special meeting of the Association held since such preceding Annual Meeting.
 - d. Reports of officers.
 - e. New business.
 - f. Election of officers.
 - g. Adjournment.

2. A special meeting of the Association shall be held upon call of the President, upon written request by the Fleet Secretaries of at least 25% of the total number of chartered Fleets then in good standing, or upon written request of majority then in office of the Governing Committee. Such call or request for a special meeting shall be addressed to the Secretary/Treasurer, and shall set forth the time, place and purpose of such special meeting. At least two weeks' written notice of the time, place and purposes of such meeting shall be given by the Secretary/Treasurer to all Secretaries of Fleets then in good standing.
3. A quorum at the Annual Meeting shall consist of such fleets as are represented in person by a fleet member or by written proxy signed by the Fleet Secretary running to an active member of the Association. A quorum at a special meeting shall consist of not less than onequarter of the total numbers of Fleets then in good standing. A Fleet may be represented at such special meeting in person or by proxy.
4. Voting at an Annual Meeting or special meeting shall be by fleet, each fleet to have one vote which shall be cast by a fleet member who has been designated fleet delegate. Proxy votes shall be cast by an active member to whom such proxy runs.

ARTICLE XI Amendments

Amendments to this Constitution and to the Plans, Rules and Specifications and Rules and Regulations Governing the International Championship may be proposed by a majority vote of the Fleets properly represented at an annual Meeting or special meeting or by a majority of the Governing Committee. Such proposed amendment shall be submitted to the Secretary/Treasurer in writing, who shall thereupon, by means of the Class Newsletter or otherwise, submit such proposed amendment for approval or disapproval to each active member. A majority of the votes upon such proposed amendment received by the Secretary/Treasurer within thirty days of the mailing of such submission shall determine the adoption or rejection of the proposed amendment. For the purposes of this Article, an active member for the preceding fiscal year who has not paid dues for the current fiscal year, shall none the less be eligible to vote until the dues deadline for the current fiscal year. Resolutions intended for consideration at the Annual Meeting must be submitted in writing to the Secretary/Treasurer, or an appointed alternate before the scheduled start of the meeting. Only resolutions so submitted may be considered, although amendments will be allowed. Those resolutions approved for Class vote will appear in the next newsletter.

DEEDS OF GIFT

MASTERS CHAMPIONSHIP

DEED OF GIFT

KNOW ALL PERSONS BY THESE PRESENTS:

That John L. Huff of Chicago, Illinois, James D. Stone of Macatawa, Michigan, the VanderBerg Family of Holland, Michigan, International 110 Fleet 36 of Bay City, Michigan, and Joseph Berkeley of Hull, Massachusetts, for the purpose of encouraging International 110 Class yacht racing, and especially in the way of friendly contests in sailing and seamanship among senior sailors, do hereby give to the International 110 Class Foundation, a charitable not-for-profit corporation created under the laws of the State of Michigan, United States of America, the scale model of an International 110 yacht (the "Trophy") delivered herewith, to be held, carried and sailed for under the following conditions:

- First: The name of the Trophy shall be the "International 110 Class Masters Championship Trophy." The short name of the Trophy shall be the "VanderBerg Trophy." The name of the competition for the Trophy shall be the "International 110 Class Masters Championship Regatta."

- Second: All qualified members of the International 110 Class Association are challenged and encouraged to enter and participate in the Masters Championship.

- Third: Title to the Trophy shall be in the International 110 Class Foundation or its successor. A winner of the Trophy shall be entitled to possess it until it is awarded to a winner in a subsequent year. In case the International 110 Class Association should for any cause be dissolved without a successor or otherwise cease to exist or actively operate for a period of more than five years, then the title to the Trophy shall transfer to the last winner thereof.

- Fourth: The Trophy shall be the object of friendly, intense competition during, as part of, and on the same race course as, the annual overall Championship Regatta of the International 110 Class. Each race comprising the annual overall Championship Regatta in which the wind velocity never exceeded 18 knots, as determined by the Race Committee, shall qualify and be counted toward the Masters Championship. A minimum of three

completed qualifying races, and a minimum of four qualifying skippers entered in the Masters Championship Regatta, shall constitute a valid Masters Championship Regatta, the overall winner of which shall be awarded the Trophy. The racing rules, regulations and scoring system for the Masters Championship Regatta shall be the same as those applicable to the annual overall Championship Regatta, except as otherwise provided herein. Daily, cumulative and final race results and standings for the Masters Championship shall be posted and reported separately and in addition to those posted and reported for the overall Championship Regatta.

Fifth: The skipper of the International 110 winning the Trophy shall be entitled to have engraved on the next consecutive plate provided with the Trophy the following: the year of the Masters Championship Regatta, the name of the winning yacht, and the names of the winning skipper and crew. The winning skipper shall be responsible for the proper, safe transportation of the Trophy, in the shipping crate provided, to the site of the following year's International 110 Championship Regatta.

Sixth: Contestants for the Trophy shall meet the following entry qualifications in addition to those established by the International 110 Class for its annual overall Championship Regatta: The skipper shall be at least fifty-five years of age in the year of that particular regatta; the crew may be any age; the qualifying skipper shall be the helmsperson of the yacht throughout every race counted in the competition for the Trophy. In the event there are less than four qualifying skipper entrants who meet the aforesaid minimum age for the Masters Championship Regatta in a particular year, then the National Championship Committee of the host fleet may reduce said minimum qualifying age in one year increments (but no younger than fifty-three years of age) for that particular regatta until there are four qualifying skippers for the Masters Championship Regatta. In the event there are less than four qualifying skippers fifty-three years of age or older, then the Trophy shall not be awarded for that year.

Seventh: The Notice of Race for the annual International 110 Championship Regatta shall include a notice of the Masters Championship Regatta, together with a statement of the aforesaid entry qualifications for the Masters Championship. The entry form or application for the annual International 110 Championship Regatta shall include a request for the birth date of the skipper of each entering yacht. Each entering yacht whose skipper meets the minimum qualifying age as set forth above shall also be automatically entered in the Masters Championship Regatta without any cost or entry fee in addition to that charged for entry in the overall Championship Regatta.

Eighth: The International 110 Class Foundation shall establish the International 110 Masters Championship Fund in a separate account for the sole purpose of defraying the cost of engraving, maintaining, upgrading and

repairing the Trophy, to which individuals and entities may make gifts which shall be tax-deductible to the extent permitted by law. Said Fund shall be invested by the Class Treasurer in an interest-bearing money market account. No withdrawal shall be made from said Fund for any purpose other than as stated above. In the event the International 110 Class Association is dissolved or otherwise ceases to exist or actively operate for a period of more than five years, then said Fund shall be placed in the general treasury of the Class and distributed according to law.

Ninth: The International 110 Class Association shall amend its By-Laws and Championship Rules and Regulations to incorporate the terms and conditions of this Deed of Gift for the Masters Championship.

Tenth: The terms of this Deed of Gift may be modified only by written agreement, signed by each of the undersigned or his/her duly authorized successor, representative or heir.

DATED this Tenth Day of August, 1998.

By: /S/

John L. Huff

By: /S/

James D. Stone

THE VANDERBERG FAMILY

By: /S/

Mark VanderBerg

By: /S/

Kris D. Lievensen

INTERNATIONAL 110 fleet 36

By: /S/

Frederick M. Eddy, Jr.

By: /S/

MASTERS CHAMPIONSHIP – RUNNER-UP TROPHY

DEED OF GIFT

KNOW ALL PERSONS BY THESE PRESENTS:

That John L. Huff of Chicago, Illinois, for the purpose of enhancing and promoting the educational purposes of International 110 Class Foundation, a charitable not-for-profit corporation created under the laws of the State of Michigan, United States of America (the “Association”), and especially to encourage and foster maritime education, seamanship and sportsmanship among senior citizens in the United States through sailing instruction and contests, does hereby give to the Association the Nambe mounted bowl (the “Trophy”) delivered herewith. The Trophy shall be awarded under the following terms and conditions:

First: The full name of the Trophy shall be the “International 110 Class Masters Championship Runner-Up Trophy”. The name of the annual competition for the Trophy shall be the “International 110 Class Masters Championship Regatta” (the “Masters Championship”). Title to the Trophy shall be in the International 110 Class Foundation or its successor.

Second: All qualified members of the International 110 Class Association are challenged and encouraged to enter and participate in the Masters Championship. The competition for the Trophy shall be subject to the same terms, conditions and qualifications as the competition for the First Place trophy of the Masters Championship as set forth in the Deed of Gift therefor dated August 10, 1998, which are incorporated by reference herein.

Third: The Association shall amend its By-Laws and Championship Rules and Regulations to incorporate the terms and conditions of this Deed of Gift.

Fourth: The terms of this Deed of Gift may be modified only by written agreement, signed by the President of the Association with the authority of the Governing Board and by the undersigned donor or his authorized successor, representative or heir.

DATED this First Day of September, 1999.

/S/
John L. Huff

ACCEPTED:

THE INTERNATIONAL 110 CLASS ASSOCIATION

By: /S/
J.D. Stone, Its First Vice President

YOUTH CHAMPIONSHIPDEED OF GIFT

KNOW ALL PERSONS BY THESE PRESENTS:

That the VanderBerg Family of Holland, Michigan, for the purpose of enhancing and promoting the boating safety and educational purposes of International 110 Class Foundation, a charitable not-for-profit corporation created under the laws of the State of Michigan, United States of America (the "Foundation"), and especially to encourage and foster maritime education, seamanship and sportsmanship among adolescent and junior sailors in the United States through sailing instruction and contests, does hereby give to the Foundation the mounted half-model of an International 110 yacht (the "Trophy") delivered herewith, subject to the following terms and conditions:

- First: The formal name of the Trophy shall be the "International 110 Class Youth Championship Trophy." The name of the annual competition for the Trophy shall be the "International 110 Class Youth Championship Regatta" (the "Youth Championship"). Title to the Trophy shall be in the Foundation or its successor.
- Second: All qualified adolescent junior sailors are invited to join and actively participate in the Foundation and the International 110 Class Association (the "Association"), and to enter and compete in the Youth Championship. The Youth Championship shall be during, part of, and on the same racecourse as the annual International 110 Class Championship Regatta. A minimum of three qualified skipper and crew teams entered in the Youth Championship, and a minimum of three completed races in which any two or more of such teams are competitors, shall constitute a valid Youth Championship. The racing rules, regulations and scoring system of the Youth Championship shall be the same as those applicable to the International 110 Class Championship Regatta, except as otherwise provided herein. Daily, cumulative and final race results and standings for the Youth Championship shall be posted and reported separately and in addition to those posted and reported for the International 110 Class Championship Regatta.
- Third: The Youth Championship Trophy shall be awarded jointly to the winning skipper and crew, who shall be entitled to possess said Trophy until it is awarded to a winning team in a subsequent year.
- Fourth: The winning skipper and crew shall be entitled to engrave the following on the next consecutive space on the plates affixed to the Trophy: the place and year of the regatta, the name of the winning yacht, and the names of the winning skipper and crew. The winning skipper and crew shall be

responsible for preserving and protecting the Trophy while it is in their possession and control, and shall be responsible for safe delivery of the Trophy to the site of the next Youth Championship.

Fifth: Youth Championship contestants shall meet the following entry qualifications in addition to those established by the Association for the International 110 Class Championship Regatta: The skipper shall be under twenty-one years of age as of the first scheduled race of the Youth Championship. The crew may be any age.

Sixth: The Notice of Race for the International 110 Championship Regatta shall include a notice of the Youth Championship, together with a statement of the aforesaid conditions and entry qualifications. The entry form for the International 110 Class Championship Regatta shall include a request for the birth date of the skipper of each entering yacht. Each entering yacht whose skipper meets the qualifying age as set forth above shall also be automatically entered in the Youth Championship without any entry fee or action in addition to that required for entry in the International 110 Class Championship Regatta.

Seventh: The Foundation and the International 110 Class Association shall incorporate the terms and conditions of this Deed of Gift in their respective By-Laws and Championship Rules and Regulations.

Eighth: The terms of this Deed of Gift may be modified only by written agreement, signed by the President of the Foundation with the authority of the Governing Board and by the undersigned donor or his authorized successor, representative or heir.

DATED this First Day of July, 2001.

THE VANDERBERG FAMILY

By: /S/ _____
Willis VanderBerg

ACCEPTED:

THE INTERNATIONAL 110 CLASS FOUNDATION

By: /S/ _____
John L. Huff, Its President

YOUTH SCHOLARSDEED OF GIFT

KNOW ALL PERSONS BY THESE PRESENTS:

That John L. Huff of Chicago, Illinois, for the purpose of enhancing and promoting the educational purposes of the International 110 Class Foundation, a charitable not-for-profit corporation created under the laws of the State of Michigan, United States of America (the "Foundation"), and especially to encourage and foster maritime education, seamanship and sportsmanship among adolescent and junior sailors in the United States through sailing instruction and contests, does hereby pledge to match, dollar for dollar, all gifts to the Foundation up to a total of One Thousand Dollars (\$1,000.00) for the Scholarship Fund of the Foundation described herein. The scholarships described herein shall be awarded and disbursed from the Scholarship Fund pursuant to the following conditions:

- First: The full name of the Scholarship Fund shall be the "International 110 Class Youth Championship Scholarship Fund." The name of the annual competition for the scholarships provided herein shall be the "International 110 Class Youth Championship Regatta" (the "Youth Championship"). Title to the Scholarship Fund shall be in the International 110 Class Foundation or its successor.
- Second: All qualified adolescent and junior sailors are invited to join and actively participate in the Foundation, and to enter and compete in the Youth Championship. The Youth Championship shall be during, part of, and on the same racecourse as the International 110 Class Championship Regatta. A minimum of three qualified skipper and crew teams entered in the Youth Championship, and a minimum of three completed races in which any two or more of such teams are competitors, shall constitute a valid Youth Championship. The racing rules, regulations and scoring system of the Youth Championship shall be the same as those applicable to the International 110 Class Championship Regatta, except as otherwise provided herein. Daily, cumulative and final race results and standings for the Youth Championship shall be posted and reported separately and in addition to those posted and reported for the International 110 Class Championship Regatta.
- Third: The Scholarship Fund shall disburse the sum of Two Hundred Dollars (\$200.00) each to the secondary school, college or university which the winning skipper (and winning crew if s/he is a student) designates, as a scholarship for defraying a portion of their respective tuition, fees and/or cost of books. Only one scholarship shall be awarded

to a skipper, and only one scholarship shall be awarded to a crew, per calendar year. The Governing Board of the Foundation, by two-thirds vote, may change the amount of the scholarships after considering such factors as the investment performance of and cash available in the Scholarship Fund, changes in the cost of education, and the like. All scholarship disbursements shall be made so as to preserve the amateur status of the winning skipper and crew.

- Fourth: Youth Championship contestants shall meet the following entry qualifications in addition to those established by the Foundation for the International 110 Class Championship Regatta: Skipper shall be under twenty-one years of age as of the first scheduled race of the Youth Championship.
- Fifth: The Notice of Race for the International 110 Class Championship Regatta shall include a notice of the Youth Championship, together with a statement of the aforesaid conditions and entry qualifications. The entry form for the International 110 Class Championship Regatta shall include a request for the birth date of the skipper of each entering yacht. Each entering yacht whose skipper meets the qualifying age as set forth above shall also be automatically entered in the Youth Championship without any entry fee or action in addition to that required for entry in the International 110 Class Championship Regatta.
- Sixth: The Foundation shall establish an International 110 Class Youth Championship Scholarship Fund which shall include the accounts described herein. The Treasurer of the Foundation shall draw money from the accounts solely for the purposes of disbursing the aforesaid scholarships. Individuals and entities are encouraged to make gifts and bequests to the Scholarship Fund, which shall be tax-deductible to the extent permitted by law. The Scholarship Fund shall be invested by the Treasurer of the Foundation as follows: Fifty percent (50%) of the dollar value of the Scholarship Fund, but no less than the sum of Five Hundred Dollars (\$500.00) and no more than Two Thousand Five Hundred Dollars (\$2,500.00), shall be invested in what is currently known as the Cash Reserves Fund of Fidelity Investments, and the balance of the Scholarship Fund shall be invested in one or more diversified Fidelity Investments mutual funds such as those currently known as the Dividend Growth, Fidelity, Low Priced Stock and Capital Appreciation funds; provided that the aforesaid account investments, ratio and amounts may be modified by a two-thirds vote of the Governing Board of the Foundation in order to reflect changes in the amount of the scholarships, or to make any other change required by law or the rules of Fidelity Investments applicable to said accounts. The Treasurer of the Foundation shall annually transfer funds from one of the aforesaid investment accounts to the other in order to meet the aforesaid ratio and amounts in the accounts. No withdrawal from the Scholarship Fund may be made for any purpose other than as stated herein. In the event the Foundation is dissolved without a

successor or otherwise ceases to exist, or the International 110 Class Association fails to hold an annual overall class championship regatta for more than five consecutive years, then the Scholarship Fund accounts shall be liquidated and the proceeds thereof shall be placed in the general account of the Foundation and distributed according to law.

Seventh: The Foundation and the International 110 Class Association shall incorporate the terms and conditions of this Deed of Gift in their respective By-Laws and Championship Rules and Regulations.

Eighth: The terms of this Deed of Gift may be modified only by written agreement, signed by the President of the Foundation with the authority of the Governing Board and by the undersigned donor or his authorized successor, representative or heir.

DATED this First Day of May, 2001.

/S/
John L. Huff

ACCEPTED:

THE INTERNATIONAL 110 CLASS FOUNDATION

By: /S/
Daniel Nolan, Its Second Vice President

ADDENDUM TO
INTERNATIONAL 110 CLASS FOUNDATION
YOUTH CHAMPIONSHIP SCHOLARSHIP DEED OF GIFT

<u>Name of Donor</u>	<u>Date(s) of Donation(s)</u>	<u>Amount(s) of Donations</u>
John L. Huff	July 21, 2001	\$100.00

WOMEN'S CHAMPIONSHIPDEED OF GIFT

KNOW ALL PERSONS BY THESE PRESENTS:

That John L. Huff and Alice A. Huff of Chicago, Illinois, for the purpose of enhancing and promoting the boating safety and educational purposes of International 110 Class Foundation, a charitable not-for-profit corporation created under the laws of the State of Michigan, United States of America (the "Foundation"), and especially to encourage and foster maritime education, seamanship and sportsmanship among female sailors in the United States through sailing instruction and contests, do hereby give to the Foundation an engraved Nambe "Spinnaker" Serving Dish (the "Trophy") delivered herewith, subject to the following terms and conditions:

First: The formal name of the Trophy shall be the "International 110 Class Women's Championship Trophy." The name of the annual competition for the Trophy shall be the "International 110 Class Women's Championship Regatta" (the "Women's Championship"). Title to the Trophy shall be in the Foundation or its successor.

Second: All qualified female sailors are invited to join and actively participate in the Foundation and the International 110 Class Association (the "Association"), and to enter and compete in the Women's Championship. The Women's Championship shall be during, part of, and on the same racecourse as the annual International 110 Class Championship Regatta. A minimum of three qualified skipper and crew teams entered in the Women's Championship, and a minimum of three completed races in which any two or more of such teams are competitors, shall constitute a valid Women's Championship. The racing rules, regulations and scoring system of the Women's Championship shall be the same as those applicable to the International 110 Class Championship Regatta, except as otherwise provided herein. Daily, cumulative and final race results and standings for the Women's Championship shall be posted and reported separately and in addition to those posted and reported for International 110 Class Championship Regatta.

Third: The Women's Championship Trophy shall be awarded to the winning female skipper who shall be entitled to possess said Trophy until it is awarded to a winning skipper in a subsequent year.

Fourth: The winning skipper shall be entitled to engrave the following on the next consecutive space on the back of the Trophy or on the base of the Trophy: the place and year of the regatta, the name of the winning yacht, and the

names of the winning skipper and crew. The winning skipper shall be responsible for preserving and protecting the Trophy while it is in her possession and control, and shall be responsible for the safe transportation of the Trophy to the site of the next Women's Championship.

Fifth: Women's Championship contestants shall meet the following entry qualifications in addition to those established by the Association for the International 110 Class Championship Regatta: The skipper shall be female of any age and shall be the helmsperson throughout each race of the Championship Regatta; the crew may be male or female.

Sixth: The Notice of Race for the International 110 Championship Regatta shall include a notice of the Women's Championship, together with a statement of the aforesaid conditions and entry qualifications. Each entering yacht whose skipper is female shall also be automatically entered in the Women's Championship without any entry fee or action in addition to that required for entry in the International 110 Class Championship Regatta.

Seventh: The Foundation and the International 110 Class Association shall incorporate the terms and conditions of this Deed of Gift in their respective By-Laws and Championship Rules and Regulations.

Eighth: The terms of this Deed of Gift may be modified only by written agreement, signed by the President of the Foundation with the authority of the Governing Board and by the undersigned donor or his authorized successor, representative or heir.

DATED this First Day of June, 2002.

/S/
John L. Huff

/S/ _____
Alice A. Huff

ACCEPTED:

THE INTERNATIONAL 110 CLASS FOUNDATION

By: /S/ _____
Jeffrey Adam, Its First Vice President

NATIONAL CHAMPIONSHIP RULES

ARTICLE I Purpose

The purpose of the National Championship shall be to determine annually the champion of the International 110 Class by arranging for competition between the active members of the Association.

ARTICLE II Trophies

Suitable trophies and awards shall be given to the winning contestants in accordance with and governed by the deeds of gift.

ARTICLE III – Situs

1. The National Championship shall be an annual event held during a time period included in the bid. In the interest of promoting the International 110, the National Championship should be held in a different District each year and should not return to a District until the National Championship has been held in the other two Districts. Bids from the several Fleets in the eligible District shall be submitted to the Secretary/Treasurer on or before the date of the Annual Meeting. In the event of no bid having been received on or before such date, or should all bids received on or before such date be rejected, the Secretary/Treasurer shall notify Fleets of the next successive District, setting a reasonable deadline for receipt of bids. Acceptance or rejection of all bids shall be by the Governing Committee, which shall act upon bids received on or before the date of the Annual Meeting before the conclusion of the National Championship Series then in progress, and shall announce its decision at the conclusion of said series. Should bids pass to the next succeeding District, the Governing Committee shall endeavor to announce its decision with respect to all bids received from such District on or before the expiration of thirty days from the deadline for receipt of bids.
2. The responsibility for arranging and providing for the proper facilities, prizes, entertainment, and all related matters, shall rest with the Fleet on whose waters the National Championship Series is held. In this regard, it must follow all reasonable recommendations of the Governing Committee.
3. Evening entertainment is optional but it is customary to hold a commodore's reception in the evening of the first day of races and an awards reception and banquet in the evening of the last day of races. An interim evening awards ceremony or reception for daily first and other awards for races held up to that point may also be held. As one of the principal purposes of the National Championship is to foster good fellowship and the exchange of ideas among the members of the International 110 Class, a full schedule of social activities is strongly recommended.
4. The Annual Meeting should be held during the National Championship series. It is suggested that the annual meeting take place in the morning.

ARTICLE IV Entries

All current members of The International 110 Class Association are eligible to compete in the National Championship Regatta.

ARTICLE V Eligibility

1. Each entrant must be certified eligible by their Fleet and in addition must have sailed his/her own or chartered yacht, or the entrant's organization's yacht, in a representative number of 110 races in the home Fleet within the current season, and by reason of residence or normal yachting activities be qualified to represent the Fleet. This last requirement may be modified by the Governing Committee for newly formed Fleets and with respect to an individual active member who, due to military service requirements, is prevented from sailing a representative number of races in that individual's home Fleet.
2. Each yacht must be sailed by not less than two persons, i.e., a helms person and one crew person. Neither the skipper nor the crew may be substituted without permission of the Race Committee.
3. All yachts entered in the National Championship shall be measured or have a signed measurement certificate issued by the Technical Chairman of the class. All yachts shall be weighed prior to the first race of the series. Sails used in the series shall be measured and marked as approved by the Technical Chairman or a Class Measurer duly appointed by the Technical Chairman.

ARTICLE VI – National Championship Committee

1. The Fleet or the officers of the Fleet in whose waters the series is held should appoint a National Championship Committee to be in charge of the series, which is composed of chairpersons of the various subcommittees such as room reservations/ housing, programs, prizes, launching and hauling, measuring and inspecting yachts and sails, charter 110s, entertainment and Race Committee.
2. The duties of the Race Committee shall be:
 - a. To prepare the racing schedule, Notice of Race and Sailing Instructions, subject to the approval of the National Championship Committee;
 - b. To conduct the races;
 - c. To provide all marks of the course;
 - d. To nominate three judges, subject to the endorsement of the National Championship Committee;
 - e. To appoint any other necessary officials;
 - f. To make readily available to all contestants race document and necessary information regarding the series; and
 - g. To report the series results to the Secretary/Treasurer; and to do all other things necessary and proper concerning the management of such series.

ARTICLE VII Races

1. The National Championship Series shall consist of seven races which shall be held in open waters as free as possible from obstructions. At least three completed races must be sailed to constitute a National Championship Series.
2. The recommended course configurations include but are not limited to:
 - Twice around windward-leeward courses measuring 0.75 – 1.5 nautical miles (depending on wind velocity) per leg;
 - One Gold Cup course, consisting of two equilateral triangles measuring 0.75 - 1.5 nautical miles (depending on wind velocity) per leg, with an addition of a windward leg sailed to the weather mark and directly returning to the finish line located directly to leeward of the leeward mark. If deemed necessary, due to lack of wind, one triangle may be deleted from the Gold Cup course prior to the start, but if this procedure is followed, the course may not again be shortened, anything to the contrary in the following paragraph notwithstanding.
3. If racing space or conditions do not permit the foregoing course configurations or lengths the Race Committee, with the approval of the Governing Committee, may prescribe course configurations and/or lengths of legs different from the recommendations in paragraph 2.
4. In the event that the Race Committee determines that there is a substantial probability that a race will overrun the time limit, it may, either before or after the starting signal, shorten the prescribed course by a maximum of two legs. In the event a course is shortened after the starting signal, the race shall be shortened following Racing Rules of Sailing rule 32.
5. The Race Committee should start and finish all races at or directly to leeward of, the leeward mark with the exception of shortened courses, unless a different procedure is approved by the National Championship Committee prior to commencement of the series.

ARTICLE VIII General Rules

1. The National Championship Series shall be governed by the Racing Rules of Sailing (RRS), by these Rules and Regulations and by the Sailing Instructions established by the host Race Committee. In the event of a conflict between these Rules and Regulations and such Sailing Instructions, these Rules and Regulations shall govern. In the event of a conflict between these Rules and Regulations and such Racing Rules of Sailing, the Race Committee shall follow these Rules and Regulations.
2. The time limit for each race shall be two hours.
3. In the event of postponement of one or more races due to unfavorable weather conditions or for any other cause, the Race Committee shall attempt to reschedule such race or races later during the week of the series. In the event of anticipated unfavorable weather conditions, the Race Committee may run up to two more races than originally scheduled for a particular day.
4. The Host Fleet shall determine whether the series is to be wet or dry sailed. If the series is to be wet sailed, all competing yachts shall be in the water prior to the first scheduled race and shall remain in the water during the time of the entire series except by special permission of the Race Committee. The National Championship Committee may waive this rule in special cases, such as the late arrival of a yacht

due to conditions beyond the control of the competitor. For a wet-sailed series, the Notice of Race shall include the launch schedule.

5. RRS Appendix T1 shall apply. This must be stated in the Sailing Instructions.

Article IX Methods of Scoring

1. The low point system in RRS Appendix A4 shall be used.
2. Each contestant's six best of the seven races sailed shall be used to determine the standing. If less than seven races are sailed, all races shall be counted or used to determine each contestant's standing.

Article X District Championships

A District Championship shall be an annual event held on the waters of each District. Such championship shall be conducted pursuant to the Class Constitution, Rules and Regulations Governing the National Championships, Specifications and Sail Regulations, except as these may be modified or changed by rules of the Host Fleet. The time and place of such championship shall be in the discretion of the Fleets in the District, acting through the District Governor. To be recognized and to qualify as such Championship, however, such race must be held pursuant to invitation to all Fleets of the District (invitation to and participation by other District Fleets or isolated yachts outside the District is optional with the District).

ARTICLE XI Courses, Regional and District

Regattas: Windward and leeward legs should be no less than .75 miles in length unless prohibited by local conditions.

ARTICLE XII Fleet Championships

A Fleet Championship shall be an annual event held on waters in the vicinity of each Fleet. It shall be conducted pursuant to the Class Constitution, Rules and Regulations Governing the National Championships, Specifications and Sail Regulations, except as modified or changed by the Fleet rules.

ARTICLE XIII Sail Numbers

Each yacht must sail with sail numbers that match the yacht's hull number. In the case of a chartered yacht, the yacht may be sailed with sails numbered with the yacht hull number or the number of the chartering skipper's yacht.

ARTICLE XIV Masters Championship

There is hereby established The International 110 Class Masters Championship Regatta ("Masters Championship") pursuant to the following terms and conditions:

1. Masters Championship contestants shall meet the following entry qualifications in addition to those established by the International 110 Class for its annual overall National Championship. The skipper shall be at least fifty-five years of age in the year of that particular regatta; the crew may be any age; and the qualifying skipper shall be the helmsperson of the yacht throughout every race counted in the competition. In the event there are less than four qualifying skipper entrants who meet the aforesaid minimum age for the Masters Championship in a particular year, then the National Championship Committee of the host fleet may reduce said minimum qualifying age in one year increments (but no younger than fifty-three years of age) for that particular regatta until there are four qualifying skippers for the Masters Championship. In the event there are less than four qualifying skippers fifty-three years of age or older, then the Masters Championship shall not be held that year.
2. The Masters Championship shall be the object of friendly, intense competition during, as part of, and on the same race course as, the overall National Championship. Each race comprising the National Championship Regatta, in which the wind velocity never exceeds 18 knots, as determined by the Race Committee, shall qualify and be counted toward the Masters Championship. A minimum of three completed qualifying races, and a minimum of four qualifying skippers entered in the Masters Championship shall constitute a valid Masters Championship. The racing rules, regulations and scoring system for the Masters Championship shall be the same as those applicable to the National Championship, except as otherwise provided herein. Contestants in the Masters Championship shall also be contestants in the National Championship. Daily, cumulative and final race results and standings for the Masters Championship shall be posted and reported separately and in addition to those of the National Championship.
3. The winner of the Masters Championship shall be awarded the "VanderBerg Trophy" which is a scale model of International 110 number 213. The runner-up of the Masters Championship shall be awarded the Nambe bowl mounted on a wooden base.
4. Title to the aforesaid trophies remain in the International 110 Class Foundation or its successor pursuant to their respective deeds of gift. Awardees of the trophies shall be entitled to possess them until they are awarded in a subsequent year. If the International 110 Class Association should for any cause be dissolved without a successor or otherwise cease to exist or actively operate for a period of more than five years, then the title to the trophies shall transfer to the last awardee thereof.
5. The awardees of each trophy shall be entitled to have engraved on the next consecutive plate provided with the trophies the following: the year of the Masters Championship, the name of the yacht, and the names of the skipper and crew to whom the trophy is awarded. The skipper to whom each trophy is awarded shall be responsible for the proper, safe transportation of the trophy to the site of the following year's National Championship Regatta.
6. The Notice of Race for the National Championship Regatta shall include a notice of the Masters Championship, together with a statement of the aforesaid entry qualifications for the Masters Championship. The entry form for the National Championship Regatta shall include a request for the birth date of the skipper of

each entering yacht. Each entering yacht whose skipper meets the minimum qualifying age as set forth above shall also be automatically entered in the Masters Championship without any cost or entry fee in addition to that charged for entry in the overall National Championship Regatta.

7. There is hereby established the International 110 Masters Championship Fund which shall be a separate account for the sole purpose of defraying the cost of maintaining, upgrading and repairing the trophies. Members of the class and other interested individuals are encouraged to make gifts. Said Fund shall be invested by the Class Treasurer in an interest-bearing money market account. No withdrawal shall be made from said Fund for any purpose other than as stated above. In the event the International 110 Class Association is dissolved or otherwise ceases to exist or actively operate for a period of more than five years, then said Fund shall be placed in the general treasury of the Class and distributed according to law.

ARTICLE XV Youth Championship

There is hereby established The International 110 Class Youth Championship Regatta ("Youth Championship") pursuant to the following terms and conditions:

1. Youth Championship contestants shall meet the following entry qualifications in addition to those established by the International 110 Class for its annual overall National Championship: Skipper shall be under twenty-one years of age as of the first scheduled race of the Youth Championship and shall be the helmsperson throughout each race of the National Championship Regatta.
2. All qualified junior sailors are invited to join and actively participate in the International 110 Class Association, and to enter and compete in the Youth Championship. The Youth Championship shall be during, part of, and on the same race course as the overall National Championship. A minimum of three qualified skipper and crew teams entered in the Youth Championship, and a minimum of three completed races in which any two or more of such teams are competitors, shall constitute a valid Youth Championship. The racing rules, regulations and scoring system of the Youth Championship shall be the same as those applicable to the annual National Championship, except as otherwise provided herein. Contestants in the Youth Championship shall also be contestants in the National Championship. Daily, cumulative and final race results and standings for the Youth Championship shall be posted and reported separately and in addition to those posted and reported for the overall National Championship.
3. The winners of the Youth Championship shall be awarded the "Glider Trophy" which is a mounted half-model of International 110 number 754. The Trophy shall be awarded jointly to the winning skipper and crew, who shall be entitled to possess it until it is awarded to a winning team in a subsequent year. The winners of the trophy shall be entitled to have engraved on the next consecutive plate provided with the trophy the following: the year of the Youth Championship, the name of the winning yacht, and the names of the winning skipper and crew. The skipper and crew to whom each trophy is awarded shall be responsible for the proper, safe transportation of the trophy to the site of the following year's National Championship Regatta.
4. Title to the aforesaid trophy shall remain in the International 110 Class Foundation or its successor pursuant to its deed of gift. A winner of the trophy shall be entitled to possess it until it is awarded to a winner in a subsequent year. If the International 110 Class Association should for any cause be dissolved without a successor or

otherwise cease to exist or actively operate for a period of more than five years, then the title to the trophy shall transfer to the last winner thereof.

5. The Notice of Race for the annual National Championship Regatta shall include a notice of the Youth Championship, together with a statement of the aforesaid entry qualifications for the Youth Championship. The entry form for the overall National Championship Regatta shall include a request for the birth date of the skipper of each entering yacht. Each entering yacht whose skipper meets the qualifying age as set forth above shall also be automatically entered in the Youth Championship without any cost or entry fee in addition to that charged for entry in the overall Championship Regatta.

ARTICLE XVI – Women’s Championship

There is hereby established The International 110 Class Women’s Championship Regatta (“Women’s Championship”) pursuant to the following terms and conditions:

1. Women’s Championship contestants shall meet the following entry qualifications in addition to those established by the International 110 Class for its annual overall National Championship. The skipper shall be female of any age and shall be the helmsperson throughout each race of the National Championship Regatta; the crew may be male or female. A minimum of three qualified skipper and crew teams entered in the Women’s Championship, and a minimum of three completed races in which any two or more of such teams are competitors, shall constitute a valid Women’s Championship.
2. All qualified female sailors are invited to join and actively participate in the Foundation and the International 110 Class Association (the “Association”), and to enter and compete in the Women’s Championship. The Women’s Championship shall be during, part of, and on the same racecourse as the annual National Championship Regatta. The racing rules, regulations and scoring system of the Women’s Championship shall be the same as those applicable to the National Championship Regatta, except as otherwise provided herein. Daily, cumulative and final race results and standings for the Women’s Championship shall be posted and reported separately and in addition to those posted and reported for National Championship Regatta
3. The Women’s Championship Trophy shall be awarded to the winning female skipper who shall be entitled to possess said Trophy until it is awarded to a winning skipper in a subsequent year. The winning skipper shall be entitled to engrave the following on the next consecutive space on the back of the Trophy or on the base of the Trophy: the place and year of the regatta, the name of the winning yacht, and the names of the winning skipper and crew. The winning skipper shall be responsible for preserving and protecting the Trophy while it is in her possession and control, and shall be responsible for the safe transportation of the Trophy to the site of the next Women’s Championship.
4. Title to the aforesaid trophy remains in the International 110 Class Foundation or its successor pursuant to its deed of gift. If the International 110 Class Association should for any cause be dissolved without a successor or otherwise cease to exist or actively operate for a period of more than five years, then the title to the trophy shall transfer to the last awardee thereof.
5. The Notice of Race for the National Championship Regatta shall include a notice of the Women’s Championship, together with a statement of the aforesaid conditions

and entry qualifications. Each entering yacht whose skipper is female shall also be automatically entered in the Women's Championship without any entry fee or action in addition to that required for entry in the National Championship Regatta.

SAIL REGULATIONS

ARTICLE I General

1. **Purchasing of Sails:** Two suits of sails may be acquired in the first calendar year of a yacht's life, and one suit each year thereafter, not to be cumulative. In the event of the loss or destruction of a sail during the year in which it was purchased, such sail may be replaced within the year, when evidence substantiating the loss is considered justified by the Fleet Officers.
2. **Dating of Sails:** Sailmakers shall indelibly mark in approximately 1" characters, at tack, the month and year of sale of each sail. Any sail submitted for measurement without having a sailmaker's date shall be assumed to have been acquired in the current year, unless it is obvious that it was acquired during an earlier year.
3. **Royalty Fee:** A royalty fee in the sum of \$5.00 shall be collected from the owner for each new sail or sail not previously stamped or marked with the date and fleet number to indicate the royalty was previously paid. The royalty fee shall be collected before said sail may be used in a Class sanctioned regatta and shall be forwarded to the Class Treasurer.
4. **Fleet Competition:** It is recommended, but not required, that sail dimensions be initially controlled at the fleet level. To this end, each fleet should require that all sails be measured before being used in fleet competition.
5. **District Competition:** For District Championship competition, sails shall conform to the regulations set forth below.
6. **International Championship Competition:** Sails shall be measured and inspected prior to the International Championship Regatta, for conformance with the following regulations. Sails that are in compliance shall be legibly marked by the measuring committee, and only such sails may be used in competition. Sails may be re-measured at any time during the regatta, at the option of the measuring committee, but retroactive disqualification as a result of such re-measurement may be imposed only in the case of intentional concealment of information during the initial measurement or subsequent willful modification.
7. **Measurement:** The sails shall be measured in accordance with the ISAF Equipment Rules of Sailing. For detailed instructions, diagrams, and images; see the, "ISAF Guide to Sail Measurement". Current documents can be located at, www.sailing.org.
8. **Objective and Certification:** Sails shall comply with the class rules in force at the time of fundamental measurement. The official measurer shall certify mainsails and headsail on the tack and spinnakers in the head and shall sign the certification mark and date it with the date of measurement.

ARTICLE II Mainsails

1. **Materials:** Mainsails may be made of any synthetic material. The weight is optional. The following are permitted: Stitching, gluing, tapes, bolt ropes, corner eyes, headboard, Cunningham eye, batten pocket patches, leach line with cleat, windows, tell tales, and draft stripes.
2. **Battens:** The maximum numbers of battens permitted shall be limited to four. The battens may be constructed of any material. The uppermost batten may extend to the luff. The battens shall divide the leech into five equal parts +/- 2". Battens below the uppermost shall not be longer than 43.5". The inside width of the batten pockets shall not exceed 2".
3. **Primary Sail Dimensions:**
 - a. *G.7.1 Foot Length:* Maximum 9' 7-1/4". Loose footed is allowed. The length of the foot shall be controlled by the mast and the band on the boom. Distance from the aft face of the mast to the inner edge of the boom band shall not exceed, 9' 7-1/4". No part of the tack shall extend forward of the aft face of the mast. No part of the clew shall extend past the inner edge of the boom band.
 - b. *G.7.2 Leech Length:* Maximum 21' 7".
 - c. *G.7.3 Luff Length:* Maximum 19' 6-1/4". The length of the luff shall be controlled by the bands on the mast. No part of the head shall extend beyond the bottom of the upper mast band. No part of the tack shall extend below the top of the lower mast band.
 - d. *G.7.5 Half Width:* Maximum 6' 7"
 - e. *G.7.6 Three-Quarter Width:* Maximum 4'
 - f. *G.7.7 Upper Width:* Maximum 17". Located 12" down from the top of the headboard and 90 degrees to the luff.
 - g. *G.7.8 Top Width:* Maximum 6-3/4"
4. **Insignia and Numbers:** The Class Insignia "110" and registered racing number in figures not less than 8" high and not less than 2" block width in any contrasting color shall be affixed to both sides of the mainsail in the manner shown in the following example:

110
231

110
231

The Class Insignia shall be superimposed with the Class Logo. The Class Logo is a figure forming a lens shape, comprising two intersecting circular arcs joined at the end points. The shape is a representation of the plan view (top view) of a 110 hull. The arcs have a radius of 3/2 the length of the figure. The suggested size of the logo is 24" long, 4" wide, formed by 2 intersecting arcs 36" long. A figure slightly larger or smaller may be used in the same proportions. Any contrasting color may be used. See sketch on following page.

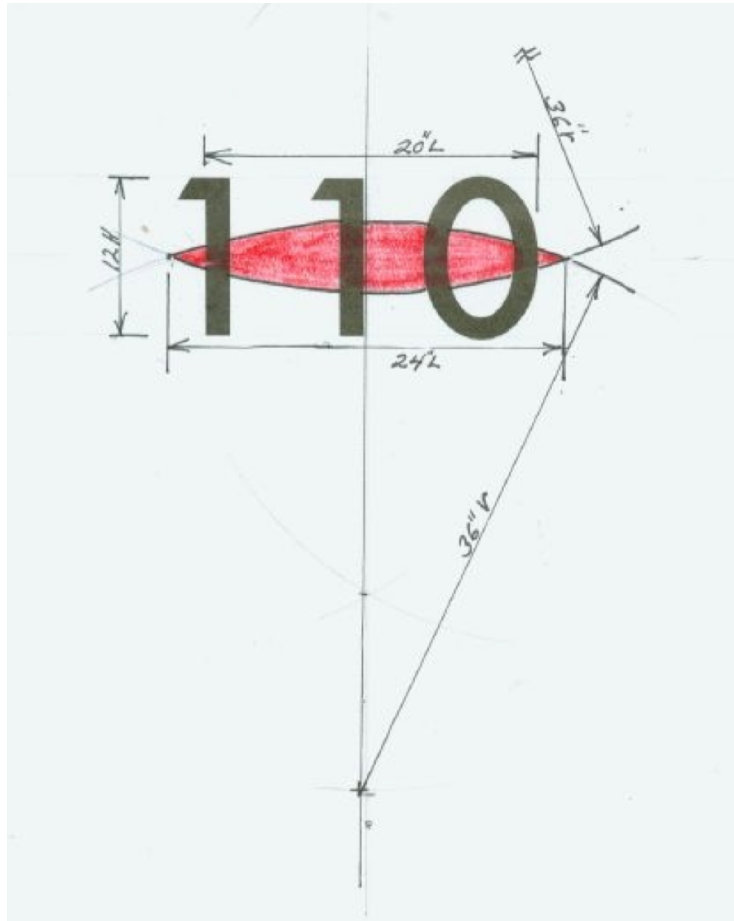

5. **Chevrons:** Chevrons shall be of the dimensions indicated on the following diagram:

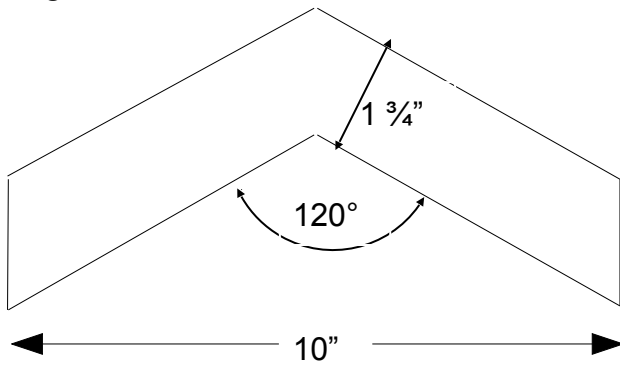

- a. Chevrons may be displayed on the mainsail at any point above the lower batten. Chevrons shall be attached with the vertex upward.

- b. The following chevron colors denote the type of Championship won:
- | | |
|----------------------------|--------|
| International Championship | Gold |
| Atlantic Championship | Silver |
| Great Lakes Championship | Orange |
| Pacific Championship | Green |
| District Championship | Blue |
| Fleet Championship | Red |
- c. Chevrons are awarded not to the yacht, but to the skipper and shall be retained by the skipper for use on any 110 that s/he may sail while still a member of the Association.

ARTICLE III GENOA

- Materials:** Genoas may be made of any material. The weight is optional. The following are permitted: Stitching, gluing, tapes, snap hanks or zipper luff, corner eyes, Cunningham eye, leach line with cleat, foot line with cleat, windows, tell tales, and draft stripes.
- Sail Reinforcement and Battens:** No battens or headboards, oversized grommets shall be permitted. Primary reinforcement is allowed, but no secondary reinforcement is allowed.
 - Jibs with a foot length of no more than 93" may have battens.
- Primary Sail Dimensions:**
 - G.7.1 Foot Length:* Maximum 10'
 - G.7.2 Leech Length:* Maximum 15'
 - G.7.3 Luff Length:* Maximum 15'- $\frac{3}{4}$ "
 - G.7.5 Half Width:* Maximum 4'-8"
- Windows:** A portion of the sail near the foot may be made of transparent plastic material. This shall be limited to a reasonable area for viewing purposes, and shall present a minimum compromise of the intent of any of the accompanying regulations. Two additional windows are allowed not to exceed 100 square inches each.

ARTICLE IV SPINNAKERS

- Number of spinnakers:** No more than two spinnakers shall be carried on board during a race. In the International Championship only, sail changes from symmetrical to asymmetrical and vice versa shall not be made during a race day. Only one spinnaker may be used at a time.
- Materials:** Spinnakers may be made of any woven material. The weight is optional.
- Sail Reinforcement:** No battens or headboards, oversized grommets shall be permitted. Primary reinforcement is allowed. Secondary reinforcement is allowed at a sail recovery point.

4. **Racing Number:** The registered racing number, in figures not less than 8" high and not less than 2" block width in any contrasting color shall be affixed to at least one side of the spinnaker. The class Insignia "110" need not be displayed on the spinnaker.
5. **Symmetrical Spinnakers:** Basic dimensions:
 - a. *G.7.1 Foot Length:* Maximum 12'
 - b. *G.7.2 Leech Length:* Maximum 16'-6"
 - c. *G.7.4 Quarter Width:* Maximum 12'-6"
 - d. *G.7.5 Half Width:* Maximum 12'
 - e. *G.7.6 Three-Quarter Width:* Maximum 8'-6"
6. **Asymmetrical Spinnakers**
 - a. Basic Dimensions:
 - i. *G.7.1 Luff Length:* Maximum 21'
 - ii. *G.7.2 The Half Width* must be greater than 75% of the Foot Length
 - b. Sail Area: Maximum sail area shall be 220.4 SF as measured by the following formula:
$$SA = [(luff\ length + leech\ length) * 0.25 * foot\ length] + [(half\ width - 0.5 * foot\ length) * (leech\ length + luff\ length)] / 3$$
 - c. An adjustable tack line may be used with an asymmetrical spinnaker. An asymmetrical spinnaker shall be tacked to the deck along the centerline of the boat not forward of the bow and not aft of the forestay.
 - d. The spinnaker pole shall not be used with an asymmetrical spinnaker.

RULES AND SPECIFICATIONS

ARTICLE I General

1. **Builders:** The International 110 Class Association has full control in the building of all 110 Class yachts to the extent of refusing to register and assign a number to any new yachts. A new yacht may be constructed only from the official plans issued by the Association, as revised from time to time by proper vote or action, or, if constructed of fiberglass, from molds or forms approved by the Association. Home building is encouraged, but the strict requirements imposed on commercial builders apply equally to home builders.
2. **Plans:** Preservation of the onedesign feature is paramount, and the plans issued by the Association's Secretary as amended from time to time shall be strictly adhered to.
3. **Measurement Certificate and Boat Registration:** Each yacht must be measured and registered prior to its participation in Association sanctioned races. This requirement applies to all yachts regardless of builder. An owner may apply for registration as follows:
 - a. He must submit the yacht for measurement to a Class Measurer. The name and address of the nearest Class Measurer may be obtained from the Secretary.
 - b. Send the completed measurement form to the Technical Chairman, who will in turn advise the Secretary when it has been determined that all measurements are within tolerance. The Secretary is then authorized to issue the required boat number. A number, when issued and assigned to a yacht, shall remain the number of such yacht, regardless of transfer or change of ownership, and may not be reissued.
 - c. Each Yacht Owner must maintain and present the measurement certificate upon request. Any changes made by the owner to the yacht will require appropriate remeasurement as determined by the Technical Chairman and notification on the certificate.
4. **Protection of Name and Emblem:** No yacht may be sold or entered in any race as a 110, or at any time display the 110 emblem upon its sails or otherwise, unless the number license fee on such yacht has been paid to the Treasurer by the builder or owner thereof, and a certificate issued. For the benefit of owners, and prospective owners, the Association shall take whatever steps may be necessary to protect both the 110 name and emblem from any unauthorized use.

- 5. Specifications:** Specifications, however complete, cannot anticipate every possible situation that may arise. If a point is not herein covered or governed by the dictates of common sense, a ruling must be obtained from the Technical Chairman. In interpreting any point not covered, or wording of obscure meaning, the Technical Chairman shall consider the intended meaning rather than a technical misconception that might be derived from the wording and shall bear in mind at all times the basic principle of the specifications, which is to maintain the Class as a onedesign class. As such rulings are made they will be published in the Association's periodic newsletter. Prior rulings will be found listed in Rules and Specifications, Article II – Specifications, Section 20. This list will be supplemented with new rulings in each publication of the Handbook. Owner's shall be bound by all rulings appearing in the latest Handbook and in newsletters published since the last Handbook.
- 6. Yacht Numbers:** The yacht number must be permanently affixed to the hull in such a position that it may be read by a person inspecting the cockpit, and in such a manner that it cannot be removed without destroying the member to which is attached.
- 7. Options:** Nothing is optional in these specifications unless it is so stated.
- 8. Measurements and Allowances:** The specifications are in feet, inches and pounds in accordance with the standards of the United States Bureau of Weights and Measures. Yachts must be built to the exact dimensions given on the official drawings, Sheets 1300 to 1306 inclusive, as revised. Allowances will be made for expansion or unavoidable fractional inexactness, which are not sufficient to permit any intentional deviations. Builders are cautioned not only to forego intentional deviations, but to see that the workmanship is of such quality that inexactness is kept to an irreducible minimum. The measurers shall be instructed not to approve yachts which are not built with reasonably high skill and careful workmanship. The measurer shall be required to measure those items called for on the Measurement Certificate Form. Forms are available from the Technical Chairman (a copy of the form can be found in this handbook, on pages T-12 and T-13). The completed form must be checked against the established tolerances and if warranted, approved by the Technical Chairman prior to a number being issued.

ARTICLE II Specifications

1. Keel

a. General: The keel is to be an iron casting as shown in the plans, weighing three hundred pounds. There shall be an allowance of plus or minus five percent in the weight. The keel must be cast from a mold made from a Class approved pattern; in addition, several critical dimensions, as specified on the measurement form, will be taken and evaluated by the Technical Committee to insure that the mold did not distort during the casting operation.

b. Keel Alterations: After a keel is cast, it is accepted as legal on the basis of three tests, each of which must be met:

- It has been cast from an approved pattern.
- It conforms to the two check dimensions specified on the New Yacht Measurement Sheet.
- It is on weight.

Keels may be altered by grinding or building up, so long as the shape of the keel is not beyond the keel measurements. Grinding the keel and building up with lightweight material is prohibited other than for fairing for shape purposes. A boat may have its keel dimensions altered or modified so as not to exceed implied maximums or minimums stated herein.

- Cut bottom of keel bulb - cut square at desired depth. Fair as needed.
- Add to bottom of keel bulb - add cast iron or steel plate of needed thickness cut to bulb shape. Keel bulb bottom and new plate must be cleaned to "white metal". The plate shall be fastened to the keel with a minimum of two(2) 3/8 inch stainless steel bolts and epoxy with microfiber additive. Fair as needed.
- Cut keel bulb top - remove material as required by cutting and grinding. Fair as needed.
- Add to keel bulb top - aft of the web, add cast iron or steel plate of needed thickness cut to bulb shape. Keel bulb top and plate must be cleaned to "white metal". The plate shall be fastened to the keel with a minimum of two(2) 3/8 inch stainless steel bolts and epoxy with microfiber additive. In the web area fair with epoxy with colloidal silica additive. Fair as needed.
- Materials - No other materials are approved when adding to the top or bottom of the keels except lightweight fairing filler may be used to a reasonably minimal extent for the purpose of surface fairing.

Drilling and plugging with heavier or lighter materials is prohibited. Keels altered beyond these limits are not legal and may not be used in official races.

c. Keel location: The keel is to be fastened to the hull at the position (KG) indicated in the plans. KG is from station 5 to the intersection of the leading edge of the keel web and the bottom of the boat. The keel may be faired to the bottom of the yacht. This may be accomplished by putty, surfacing compounds, or other similar products.

- d. Keel Bulb Definition:** The keel bulb is any portion of keel below and including the upper most bulb chord. A bulb chord must have a fore and aft length which is 31.500 ± 0.625 inches and has a maximum width no greater than 3.500 inches but not less than 3.000 inches. At no point below the upper most bulb chord and above the lower most bulb chord may the keel not comply with the above stated maximum and minimum chord lengths and widths. The lowest most bulb chord must be no higher than 1.500 inches above the lowest point of the keel.
- e. Web Shape:** Web shape at the top of the web (up to 2.000 inches below the bottom of the boat) shall not be smaller in any dimension than the boat's web dimensions, but may be larger. Trailer tie down gear wear no greater than 1.000 inch forward and 1.000 inch vertically at the rear of the upper web is permissible as an exception. Web shape at the bottom of the web must begin no higher than 1.000 inches above the upper most bulb chord. The web diagonal length must have a length of 14.500 inches maximum and has a width no greater than 1.500 inches but not less than 0.75 inches.
- f. Keel to Chine Measurements:** Chine to lower most keel point measurement shall be taken at keel depth location (KA). The minimum measurement shall be 30.000 inches, which is the minimum crown plus the minimum keel depth ($M+KA=1.5''+28.5''$). The maximum measurement shall be 32.000 inches, which is the maximum crown plus the maximum keel depth ($M+KA=2.0''+30.000''$). The chine to keel measurement is based on the plane that is parallel to the designers theoretical base line and contains two bottom points, one on the starboard side, and the other on the port side of the boat. Each point is 1.375 inches inboard of the lower most tangent plane to the topside. Keel bulb and keel web chords are measured parallel to this chine plane. The chine to top of keel bulb chord shall not exceed 19.000 inches. Minimum to be 16.875 inches.
- Conflict between chine measured versus bottom measured dimensions shall be resolved in the case of the upper most bulb chord in favor of that which makes the web shorter. In the case of lower most keel point neither maximum depth must be exceeded.
- g. Keel Measurements:**
- Keel depth (KA) from the bottom of the boat shall not exceed 30.000 inches. Minimum keel depth is 28.500 inches.
 - Keel bulb height (KB) shall not exceed 13.000 inches. Minimum keel bulb height is 12.250 inches. KB is from the bottom most point of the keel to the upper most bulb chord.
 - Keel bulb length (KC) shall not exceed 32.125 inches. Minimum keel bulb length is 30.875 inches.
 - Keel bulb width (KD) shall not exceed 3.500 inches. Minimum keel bulb width is 3.000 inches.
 - Keel web diagonal (KE) shall not exceed 14.50 inches.
 - Keel web width (KF) shall not exceed 1.500 inches. Minimum keel web width is 0.75 inches.

- Keel web height (KH) shall not exceed 17.000 inches. Minimum keel web height is 15.375 inches.
 - Keel to chine depth (KL) shall not exceed 32.000 inches. Minimum keel to chine depth is 30.000 inches.
 - Chine to top of keel bulb chord (KM) shall not exceed 19.000 inches. Minimum chine to top of keel bulb chord is 16.875 inches.
 - The location of measurements KA, KB, KH, KL, KM is 53.000 inches aft of station # 5. For the purposes of these measurements, station #5 is located at the forward side of the forward coaming in it's normal position.
- h. Existing Boats:** All keels shorter than 28.500 inches shall be grandfathered as legal. All keels deeper than 30.000 inches shall be corrected to comply with the aforementioned requirements no later than May 1, 2000.
- 2. Rudder and Tiller:** The rudder may be made of any suitable material. The thickness of the finished rudder shall not exceed 1 1/4" at any point, except for rudders constructed with an external jaw type shaft where the thickness shall not exceed 1 3/4" for more than ten inches below the bottom of the hull. Generally, the flushtothetbottom type of rudder is acceptable so long as it meets all other published requirements. Corner radii are optional. The tiller shall be of a suitable material. A tiller extension (hiking stick) is permitted.
- 3. Planking:** Bottom, topsides and decks are to be made of 3/8 " marine resin plywood, three or more ply, fir or any other facing desired, finished at least on one side. The plywood may have an impregnated Kraft fiber overlay. The chines shall be of Douglas fir or equivalent wood. This section does not apply to yachts of fiberglass construction. 9mm plywood (European material) may be substituted for 3/8 inch marine resin plywood.
- 4. Floors, Frames, Deck Beams and Butt Blocks:** Shall be as shown on the plans. Equivalent materials may be substituted. This section does not apply to yachts of fiberglass construction.
- 5. Flotation:** Wooden yachts with bulkheads installed that effectively close off the ends of the cockpit so that the ends of the yacht are sealed against of entry of water must have 300 pounds of flotation installed. Wooden yachts without such bulkheads must have 600 pounds of flotation installed. Fiberglass yachts must have 400 pounds of flotation installed. Flotation will be made of such material as styrofoam which will not lose flotation effectiveness because of puncture or chemical disintegration. Air bags equal to the flotation as stated above may be used, but at least four bags will be required for a yacht without bulkheads, at least two bags for yachts with bulkheads.
- Holes will be allowed in bulkheads for the passage of control lines. Limber holes in the floor beams shall not be sealed off so that water that enters the ends of the yacht through fitting holes or spinnaker launching elbows may drain into the cockpit area.
- 6. Stem and Stern:** Shall be of oak or equivalent wood and follow the specifications shown on the plans. This section does not apply to fiberglass yachts.

- 7. Cockpit:** The cockpit shall be of the size and shape as shown on the plans. The coaming shall be of the size and shape as shown on the plans. The coaming shall be of ½ inch minimum thickness of suitable material. The extent of required coaming is well defined in the plans, specifically, the required "Vportion" forward of the mast is required. The 3 inch height above the deck may be reduced abaft the main shrouds, but in no place shall the top be less than 1 inch above the deck. The coaming extension aft of the cockpit is not required. The fairing of the coaming from the deck level to the top of the coaming is allowed (i.e., "Fanny rests").
- 8. Splashboard:** The splashboard shall be fixed at 60° to the deck at the location shown on the plans (3' 6" forward of station #5). The splashboard must be at least ½ inch thick. Material used is optional. The lower edge must approximately match the deck curve and fit closely to the deck. It shall have a constant width of 31/8 inches except that it may begin to curve to the deck 5½ inches from the ends (at 2¾ inches from the ends, 2½ inches high). It shall be 29¾ inches long measured to the inside edge of any notches used to retain spinnaker sheets. The upper edge may be rounded but not notched or cut out. This is to define the absolute minimum size of the splashboard necessary on a 110. Folding splashboards are not permitted.
- 9. Floorboards:** Floorboards are required, and shall cover the entire cockpit area, so as to prevent the possibility of stepping on the bottom of the yacht. The space under the thwart or bridgedeck if fitted may be left uncovered for bailing.
- 10. Joints (Wooden boats):** All joints shall be glued and fastenings are not required if the West® (wood epoxy saturation technique) or equivalent type of gluing systems are used.
- 11. Optional Items:**
- a. Crossbeam:** The crossbeam or bridgedeck if fitted, may be of any design and of any material, but is not required.
 - b. Lockers and Shelves:** The addition of lockers and shelves on the inside of the hull is permitted.
 - c. Rails:** Foot and handrails may be attached to the fore and aft decks.
 - d. Shields:** Metal shields may be attached to the bow and stern.
 - e. Traveler:** A mainsheet traveler may be located within a 3 inch strip beginning 21 inches aft of the afterface of the aftercoaming. No part of the traveler may extend beyond the intersection of the deck and the deck chines. The method of attachment and details of construction are optional. Except for this traveler arrangement, the mainsheet rig may not be altered from the design and location as shown on the plans.
 - f. Rub Rails:** A single rub rail not more than ¾ inch x 1¼ inch may be affixed to each side of the boat, no lower than 6 inches below deck level.
 - g. Jib Sheet Barberhaulers and Up-Down Controls:** Allowed, location is optional with the following exceptions:
 - Such controls shall not allow the clew of any size jib or genoa to be sheeted further inboard than the Working Deck.
 - Such controls shall not be fitted outboard of the Working Deck.
 - h. Jib Sheet Underdeck Systems:** Allowed.
 - i. Spinnaker Launching Tube:** Thru deck spinnaker launching tubes are allowed and may be used in any 110 sanctioned race. The opening in the deck should be no more than 12 inches by 12 inches and should be fitted with a hatch or cover.
 - j. Trapeze:** A single trapeze is permitted in all 110 competition.

- k. **Cleats and Chocks:** Cleats and chocks are not required equipment and the use of a hole in the deck through which the painter is led is legal.
- l. **Endless Spinnaker Halyard:** An endless spinnaker halyard is legal.
- m. **VHF Radios:** VHF Radios are approved as optional equipment; such use is limited to monitor information and instructions from Race Committee, weather information and general marine broadcasts. Use of radios during racing for 2-way communication is prohibited, except for distress calls or notification of “withdrawal” from the race.”

12. Spars:

a. Mast

- Metal Mast Dimensions:

Fore and aft dimension minimum	23/8"
Side width dimension minimum	21/8"
45° to fore and aft dimension minimum.....	23/8"
Side width dimension at upper mast band minimum.....	21/8"
Fore and aft dimension at upper mast band minimum	15/16"
45° to fore and aft dimension at upper mast band minimum	11/8"

If tapered, taper can begin no less than 14' 9" measured up from butt.
 Minimum tip weight is 8 1/2 pounds with mast completely rigged, less backstay, trapeze wire, wind pennant or other optional equipment; with halyards in hoisted position and shrouds taped to mast at butt. To measure, support mast at butt and place scale at upper mast band.
- The mast step shall be located on the keelson cover plank (or equivalent location on a fiberglass boat). The distance from the upper surface of the deck, projected to a point directly above the mast step shall be 17 1/4 inches plus or minus 2 inches. (dimension "A" in mast Drawing)
- To indicate the deck height on the mast, a line shall be marked around all sides of the mast at deck level. A deck band of at least 1" in width, of contrasting color, shall be painted below the deck height elevation, to define the measuring point for the controlled dimensions – deck to upper band (dimension “MB”), deck to spinnaker halyard (dimension “MC”), deck to jib stay (dimension “MD”) and deck to spinnaker pole ring (dimension “ME”) as defined below.
- To indicate the maximum height to which any part of the sail head shall not extend when set, a line shall be marked around all sides of the mast at a height not to exceed 21' 1/2" above deck. A band of at least 1" in width of a contrasting color shall be painted above this band to define the upper mast band. (dimension "MB")
- To indicate the lowest point to which the sail tack shall extend when the sail is set, a line shall be marked around all sides of the mast at a distance not to exceed 19' 6 1/4" below the bottom of the aforementioned upper band. A band of at least one inch in width, of contrasting color, shall be painted below this line to define the lower mast band. (dimension "MF")
- The maximum distance from the deck to the center of the spinnaker halyard when the halyard is pulled 90 degrees to the mast face is 17' 0". (dimension "MC")
- The maximum distance from the deck to a point where a projection of the jib stay would intersect the forward face of the mast at an angle of 18 degrees is 16' 3/4". (dimension "MD")

- The maximum distance from the deck to the top of the spinnaker pole ring is 4' 8¹/₄". (dimension "ME")
 - Mast pushers and pullers are allowed, but no portion of the device may extend more than 3 inches above the deck level.
 - Mast steps which can be adjusted while under sail are not allowed.
- b. Boom:** The boom may be made of any material and be of any cross sectional shape so long as the finished spar, exclusive of fittings, but including sail track (if used), will pass through a 3¹/₂ inch diameter hole. The Holt Allen S7 boom section is allowed. Slotted booms are permitted. The track or slot used for the mainsail attachment must be straight in both horizontal and vertical planes.
- c. Spinnaker Pole:** The spinnaker pole shall not be longer than 6' 13³/₄" overall including the end fittings. The material use and the thickness of the pole is optional. When in use, the inboard end must be attached to the mast, except when jibing.
- d. Whisker Pole:** An additional whisker pole not to exceed 9' 6¹/₄" overall including fastenings may be used to wing out the genoa. It may not be used on the spinnaker. The material used and the thickness of the pole is optional. When in use, the inboard end must be attached to the mast.
- 13. Rigging:** The standing rigging shall be of multistrand construction, not less than 1/8 inch in diameter, 1 x 19. It shall consist of jib stay and main shrouds. Backstay shall be 1/16" diameter wire or zero stretch line of equivalent tensile strength if the backstay is fitted. No forward struts or jumper stays are permitted. The type of turnbuckles is optional. Any changes in the set of standing rigging except as occasioned by accident or by conventional turnbuckles during a race shall be prohibited. Chainplates must be on deck. The use of under deck levers or other devices to slacken the shrouds is not allowed. A single jib downhaul is permitted, fittings therefore optional. It may be used either for adjustment of the tack height or for draft control on a looseluff jib. The jib downhaul shall not be attached to the jib stay in such a manner as to permit adjustment of jib stay tension from the cockpit. An adjustable masthead backstay if permitted. Fittings and devices used for this purpose are optional.
- 14. Deck, Spar and Boom Hardware:** The deck, spar and boom hardware, together with the running rigging shown in the official plans, is not absolutely fixed and equivalent fittings may be used with the following exceptions:
- The Working Deck is defined as the deck area that is inboard of the deck chine radius (1.625" inboard of the hull side), and 1.25" outboard of the cockpit coaming's inboard face.
 - The jib sheet, for any size jib or genoa, must be led through blocks or fairleads located on the Working Deck.
 - If a deck penetration is made for a jib underdeck system, such as a slot or fairlead, such penetration must be located on the Working Deck, and the maximum width of such penetration shall be 1.5"

Jib and mainsail halyard locks are permitted; their location is optional.

- 15. Finish:** The finish of the hull, rudder, keel and spars is optional, except that the use of potlead or graphite bottom paints is prohibited. The keel may be enameled, galvanized, or plated. The use of fiberglass or equivalent covering material is permitted.

16. Hiking Straps: The use of hiking straps or toe straps is permitted either longitudinally or athwartships within the cockpit. These may be either rope or canvas webbing or other suitable material fastened not higher than the bottom edge of the cockpit coaming. When fully extended, they shall not project above the deck line.

17. Boom Vang: Boom vang (boom jack or kicking strap) is permitted, provided the load is carried directly to the centerline of the yacht.

18. Hull Weight: Hull minimum weight shall be 910 pounds. Yachts to be measured with mast and boom in place, all loose equipment to be removed except spinnaker pole, and main, jib, and spinnaker sheets. The genoa may be in place. Loose equipment to be construed as such items as paddles, anchors, sails (except genoa), cushions etc.

If weight must be added, it shall be permanently affixed and distributed in the following manner -

The first 75 pounds of weight shall be distributed:

- 50% between Stations 4 and 10
- 25% placed ahead of Station 4
- 25% placed aft of Station 10.

Additional weight above 75 pounds shall be equally distributed ahead of Station 3 and aft of Station 11.

19. Fiberglass Construction: Fiberglass construction by a builder or builders approved by the Association is permitted provided that the Technical Chairman has approved such builder's Details of Construction prior to commencement of actual construction. Sections 2, 3, 5, 9 and 10 of this Article may be altered at the discretion of the Technical Chairman, to allow fiberglass construction. No alterations to these specifications may be made that will result in the outclassing of conventional wooden 110 yachts.

20. Technical Rulings:

- a. Electrical or electronic equipment is not allowed unless specifically approved.
- b. No outriggers of any purpose are permitted.
- c. Stringers may be added fore and aft between existing bottom frames.
- d. <deleted> – refer to Rules & Specifications, Article II, 11. Optional items, m. VHF Radios
- e. Side Stay chain plates shall be installed in the location shown on the plans. Tracks must have end stops. Tracks shall extend beyond the stops only the length required for proper fastening to the deck. The nominal aft position of the side stay shall be 19.5 +/- .5 inches aft of station #5. The nominal forward movement of the side stay shall be 10.5 +/- .5 inches.
- f. The use of graphite additives to epoxy is allowed as a bottom finish.
- g. Wrist watches, stop watches and countdown timers are permitted.
- h. The tacktic® Micro Compass, Model No. T061 is approved.

ARTICLE III – Rules and Specifications Diagrams

1. Keel Measurements

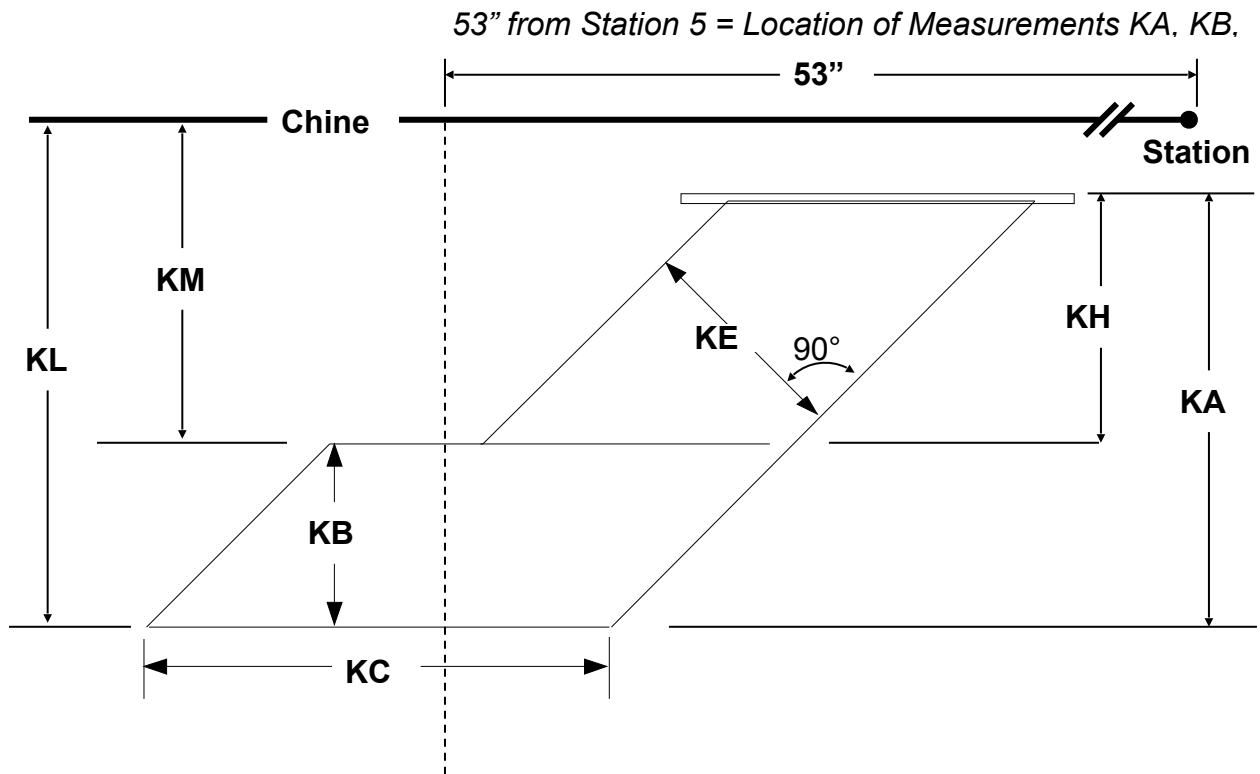

2. Rudder and Tiller Measurements

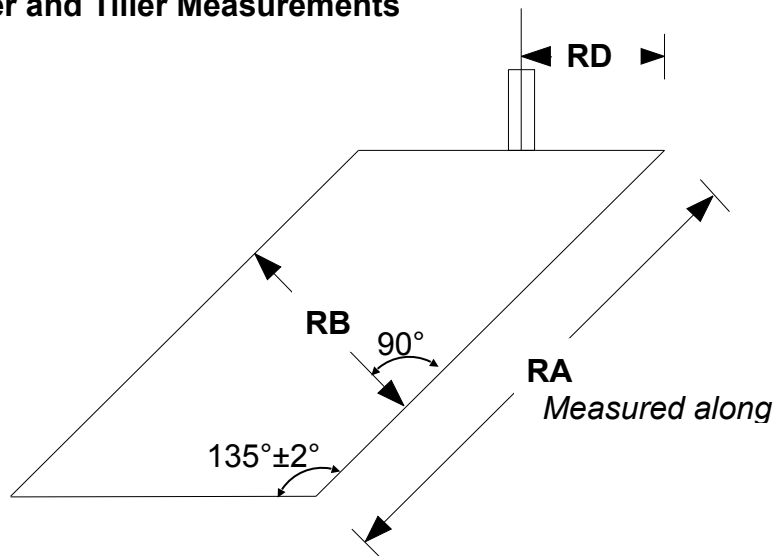

3. Spar Measurements

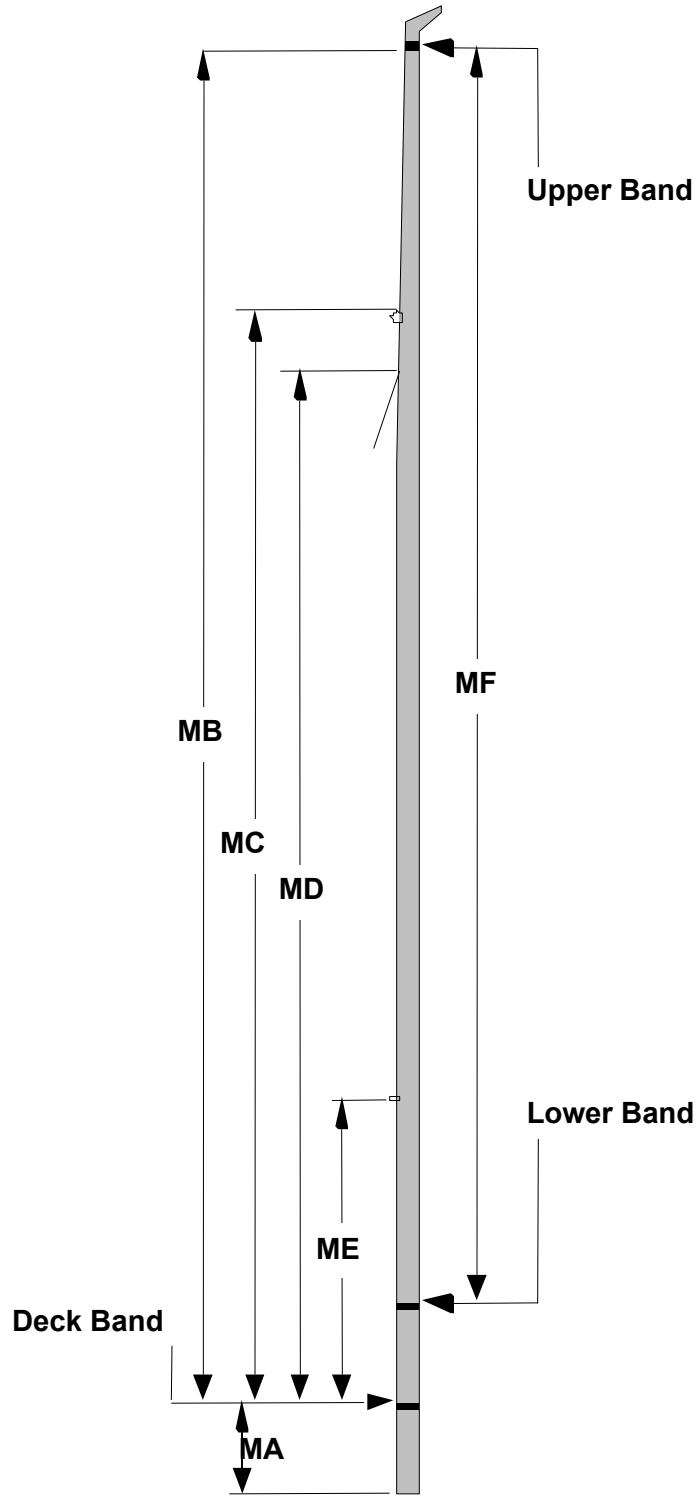

**International 110 Class Association
Measurement Certificate Worksheet**

Boat Number _____
 Builder _____ Year Built _____
 Owner _____

Measurement Description	Actual	Minimum	Nominal	Maximum	Reference	Out of Tolerance
-------------------------	--------	---------	---------	---------	-----------	------------------

HULL MEASUREMENTS: all dimensions in inches

LOA	Length overall		286.875	287.375	287.875	Plans, #1106, dim. A	
A	Topsides at bow (#0)		19.75	20.00	20.25	Plans, #1106, dim Y	
B	Topsides at Sta. #5		19.375	19.625	19.875	Plans, #1106, dim E	
C	Topsides at Sta. #10		17.375	17.625	17.875	Plans, #1106, dim F	
D	Topsides at stern (#15)		13.75	14.00	14.25	Plans, #1106, dim X	
E	Bow to Sta. #5 (f.c.)		101.50	103.00	104.50	Plans, #1106, dim P	
F	Beam at Sta. #5		45.75	46.00	46.25	Plans, #1106, dim B	
G	Beam at Sta. #7		49.75	50.00	50.25	Plans, #1102, dim C	
H	Beam at Sta. #10		44.25	44.50	44.75	Plans, #1102, dim D	
I + J	Rocker (combined)		14.875	15.375	15.875	Plans, #1102, dim I+J	
K	Sta. #5 (f.c.) to Sta. #10 (a.c.)		88.50	89.00	89.50	Plans, #1102, (calc.)	
L	Crown at Sta. #10		1.25	1.50	1.75	Plans, #1106, dim H	
M	Crown at keel depth (KA)		1.50	1.75	2.00	calculated	
GW	Gross weight lbs		910	910	n/a	Handbook pg. T-9	
CWT	Corrector weights TOTAL lbs			n/a	n/a	Handbook pg. T-9	
CWA	CW at Sta. #4 thru #10 lbs		0.00	50% of 75 lbs	37.50	Handbook pg. T-9	
CWB	CW forward of Sta. #4 lbs		0.00	25% of 75 lbs	18.75	Handbook pg. T-9	
CWC	CW aft of Sta. #10 lbs		0.00	25% of 75 lbs	18.75	Handbook pg. T-9	
CWD	CW forward of Sta. #4 lbs		0.00	50% > 75 lbs	n/a	Handbook pg. T-9	
CWE	CW aft of Sta. #11 lbs		0.00	50% > 75 lbs	n/a	Handbook pg. T-9	

DECK LAYOUT MEASUREMENTS:

N	Sta. #5 (f.c.) to headstay		56.00	57.50	59.00	Plans, #1102, dim. m	
O	Sta. #5 (f.c.) to shrouds at Sta. #6		19.00	19.50	20.00	Plans, (calc.)	
P	Forward throw of shroud car		10.00	10.50	11.00	from Merriman fitting	
Q	Combing height at "V"		2.50	3.50	4.50	Plans vary from 2.5 to 4.5	
R	Aft combing height		1.00	1.625	2.25	Plans, #1102	
S	Splashboard at deck to Sta.#5 (f.c.)		39.50	42.50	45.50	Plans, #1301	
T	Splashboard height		2.625	3.125	3.625	Handbook T-5 (calc from width)	
U	Traveler to Sta. #10 (a.c.)		21.00	22.50	24.00	Handbook, pg. T-6	
V	Area of spinnaker launcher opening		n/a	n/a	144 sq in	Handbook, pg. T-6	

Measurement Description	Actual	Minimum	Nominal	Maximum	Reference	Out of Tolerance
-------------------------	--------	---------	---------	---------	-----------	------------------

FOIL MEASUREMENTS:

KA*	Bottom of boat to bottom of Keel bulb		28.50	28.875	30.00	Fiberglass MS, Plans 1102 & 1106	
KB*	Keel bulb height		12.25	12.50	13.00	handbook, pg. T-3	
KC	Keel bulb length		30.875	31.50	32.125	Handbook, pg. T-4, Plans #1102	
KD	Keel bulb thickness		3.00	3.25	3.50	Handbook, pg. T-3, Plans #1102	
KE	Keel web diagonal		none	14.50	14.50	Handbook, pg. T-4, Plans #1102	
KF	Keel web thickness		0.75	1.125	1.50	Handbook, pg. T-4, Plans #1102	
KG	Keel to Sta. #5 (f.c.)		8.50	9.00	9.50	Plans #1106	
KH*	Bottom of boat to top of Keel bulb		15.375	n/a	17.00	1997 Keel Proposal	
KL*	Chine to bottom of Keel bulb		30.00	n/a	32.00	1997 Keel Proposal	
KM*	Chine to top of Keel bulb		16.875	n/a	19.00	1997 Keel Proposal	
--*	Bottom of boat to upper most web chord		0.00	2.00	2.00	1997 Keel Proposal	
--*	Lower most web chord to upper most bulb chord		0.00	1.00	1.00	1997 Keel Proposal	
--*	Bottom of Keel to lower most bulb chord		0.00	1.50	1.50	1997 Keel Proposal	
RA	Rudder length along centerline		18.00	21.75	25.50	Handbook, pg. T-4, Plans #1102	
RB	Rudder diagonal		10.375	10.75	11.125	Handbook, pg. T-4, Plans #1102	
RC	Rudder thickness		0.75	1.00	1.25	Handbook, pg. T-4, Plans #1106	
RD	Rudder post location		7.50	8.25	9.00	Handbook, pg. T-4	
RE	Rudder post to Sta. #5 (f.c.)		104.25	105.00	105.75	Plans #1106, dim O	

* Measurement location is 53.00 inches aft of Station #5 (f.c.)

SPAR MEASUREMENTS:

MA	Deck to step		15.25	17.25	19.25	Handbook, pg. T-7, Section 12.2	
MB	Deck to upper band		n/a	n/a	252.50	Handbook, pg. T-7, Section 12.4	
MC	Deck to spinnaker halyard		n/a	n/a	204.00	Handbook, pg. T-7, Section 12.6	
MD	Deck to jib stay		n/a	n/a	192.75	Handbook, pg. T-8, Section 12.7	
ME	Deck to pole ring		n/a	n/a	56.25	Handbook, pg. T-7, Section 12.8	
MF	Upper band to lower band		n/a	n/a	234.25	Handbook, pg. T-7, Section 12.1	
MG	Taper begins from deck		159.75	n/a	n/a	Handbook, pg. T-7, Section 12.1	
MH	Tip weight		8.5	n/a	n/a	Handbook, pg. T-7, Section 12.1	
MI	Mast to Sta. #5 (f.c.)		0.50	3.50	6.50	Handbook	
MJ	Mast section at butt: fore/aft		2.375	n/a	n/a	Handbook, pg. T-7, Section 12.1	
MK	Mast section at butt: side width		2.125	n/a	n/a	Handbook, pg. T-7, Section 12.1	
ML	Mast section at butt: 45 degrees		2.375	n/a	n/a	Handbook, pg. T-7, Section 12.1	
MM	Section at upper band: fore/aft		1.25	n/a	n/a	Handbook, pg. T-7, Section 12.1	
MN	Section at upper band: side width		1.125	n/a	n/a	Handbook, pg. T-7, Section 12.1	
BA	Boom length: mast to band		n/a	n/a	115.25	Handbook, pg. M-1	
BB	Boom section diameter		n/a	n/a	3.50	Handbook, pg. T-8	
PA	Spinnaker pole length		73.25	73.50	73.75	Handbook, pg. T-8	
PB	Spinnaker pole diameter		1.25	1.50	1.75	Construction Manual	

COMMENTS: _____

Measurers: _____ Date Measured: _____

M-1 Form

BOAT NUMBER _____

OWNER (Charterer) _____

CREW _____

• Total weight of boat (910 pound minimum) _____ lbs.

When boat is weighed, all loose gear must be removed.

Gear allowed on boat for weigh in:

- mast and boom
- spinnaker pole
- main sheet
- jib sheets
- spinnaker sheets
- genoa

For the following items, the person completing the M-1 Form should initial the line to the right after verifying the item is in compliance.

- Floatation installed
 - Wooden boat with bulkheads: 300 lbs flotation required
 - Wooden boat without bulkheads: 600 lbs flotation required
 - Fiberglass boat with bulkheads: 400 lbs flotation required
 - Fiberglass boat without bulkheads: 700 lbs flotation required

- Required loose equipment:
 - Bucket _____
 - Paddle _____
 - Anchor & 50' Line _____
 - Life Jackets (one for each person) _____

- All sails must be measured & stamped "Royalty Paid"
 - Suit #1 _____
 - Suit #2 _____
 - Suit #3 _____

• Regatta Registration completed. _____

• Measurement Certificate completed and approved. _____
Changes made to boat since last measurement form completed? Yes No

• Comments: _____

COMPLETED BY _____ DATE _____